



Solid State Relays Zero Switching Types RGS Solid State Relay 'E' connection



- 17.5mm width
- Rated Operational voltage: Up to 600Vrms
- Rated Operational current: Up to 90Arms
- Up to 6600A²s for I²t
- Control voltages: 3-32 VDC, 20-275 VAC (24-190VDC)
- Input connection: Screw terminal or pluggable spring
- Output connection: Screw clamp/screw terminal
- Design according to IEC/EN60947-4-2, IEC/EN60947-4-3, IEC/EN62314, UL508, CSA22.2 No. 14-10
- Integrated voltage transient protection with varistor
- RoHS compliant
- Short circuit rating: 100 kA
- VDE approval

Product Description

Aim of this solid state switching device is to switch heater loads and motor loads frequently. The range offers solutions up to 90AAC in 17.5mm width. Output connections are via a screw connection, having a captivated washer allowing for safe looping. Input connection is provided either via a screw

connection having a captivated washer or via a pluggable spring loaded input. Other options with integrated heatsink are available in RGC ranges.

Specifications are at a surrounding temperature of 25°C unless otherwise specified.

Ordering Key **RGS 1 A 60 D 75 K K E**

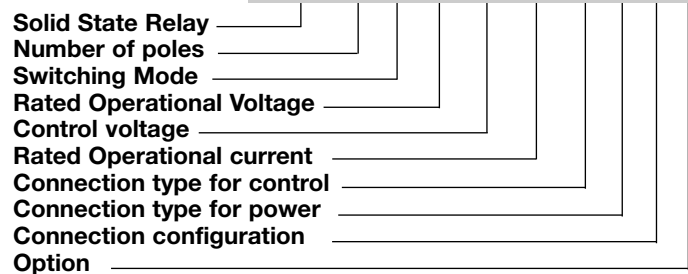

Ordering Key

| 1Phase SSR with no heatsink | Rated Voltage | Control Voltage | Rated Current | Connection Control | Connection Power | Connection Configuration | Options |
|-----------------------------|------------------------|--------------------------------|---|--------------------------|------------------|--------------------------|-------------------------|
| RGS1A: ZC | 23: 230V +10% - 15% | D: 3 - 32 VDC (4-32VDC) | 25: 25A, 1200Vp 50: 50A, 1200Vp | K: Screw M: pluggable | K: Screw | E: Contactor | HT: Thermal pad |
| RGS1B: IO | 60: 600V +10% -15% | A: 20 - 275VAC (24-190 VDC) | 51: 50A, 1600Vp 75: 75A, 1200Vp 71: 75A, 1600Vp 90: 90A, 1200Vp 91: 90A, 1600Vp | spring-loaded | | | H51: Heatsink RHS37A |

Selection Guide (ZC = Zero Cross Switching, IO = Instant-On Switching)

| Rated Output Voltage | Blocking Voltage | Connection Control/ Power | Control Voltage | Rated operational current @ 40°C | | | |
|-------------------------|---------------------|------------------------------|----------------------|----------------------------------|---------------|---------------|---------------|
| | | | | 25 AAC | 50 AAC | 75 AAC | 90 AAC |
| 230VAC, ZC | 800Vp | Screw/Screw | 3-32VDC | RGS1A23D25KKE | RGS1A23D50KKE | RGS1A23D75KKE | - |
| | | Spring/Screw | 3-32VDC | RGS1A23D25MKE | RGS1A23D50MKE | - | - |
| | | Screw/Screw | 20-275VAC, 24-190VDC | RGS1A23A25KKE | RGS1A23A50KKE | RGS1A23A75KKE | - |
| | | Spring/Screw | 20-275VAC, 24-190VDC | RGS1A23A25MKE | RGS1A23A50MKE | - | - |
| 600VAC, ZC | 1200Vp | Screw/Screw | 4-32VDC | RGS1A60D25KKE | RGS1A60D50KKE | RGS1A60D75KKE | RGS1A60D90KKE |
| | | Spring/Screw | 4-32VDC | RGS1A60D25MKE | RGS1A60D50MKE | RGS1A60D75MKE | RGS1A60D90MKE |
| | | Screw/Screw | 20-275VAC, 24-190VDC | RGS1A60A25KKE | RGS1A60A50KKE | RGS1A60A75KKE | RGS1A60A90KKE |
| | | Spring/Screw | 20-275VAC, 24-190VDC | RGS1A60A25MKE | RGS1A60A50MKE | RGS1A60A75MKE | RGS1A60A90MKE |
| | 1600Vp | Screw/Screw | 4-32VDC | - | RGS1A60D51KKE | RGS1A60D71KKE | RGS1A60D91KKE |
| | | Screw/Screw | 20-275VAC, 24-190VDC | - | RGS1A60A51KKE | RGS1A60A71KKE | RGS1A60A91KKE |
| 600VAC, IO | 1200Vp | Screw/Screw | 4-32VDC | RGS1B60D25KKE | RGS1B60D50KKE | RGS1B60D75KKE | RGS1B60D90KKE |

Selection Guide (RGS with attached Thermal Pad)¹

| Rated Output Voltage | Blocking Voltage | Connection Control/ Power | Control Voltage | Rated operational current @ 40°C | |
|-------------------------|---------------------|------------------------------|--------------------|----------------------------------|-----------------|
| | | | | 50 AAC | 90 AAC |
| 230VAC, ZC | 800Vp | Screw/Screw | 3 - 32VDC | RGS1A23D50KKEHT | - |
| | | Spring/Screw | 3 - 32VDC | RGS1A23D50MKEHT | - |
| 600VAC, ZC | 1200Vp | Screw/Screw | 4 - 32VDC | RGS1A60D50KKEHT | RGS1A60D90KKEHT |
| | | Spring/Screw | 4 - 32VDC | RGS1A60D50MKEHT | RGS1A60D90MKEHT |

1: The thermal pad with suffix 'HT' is available with any RGS part no. upon request. The above are some examples of RGS selection with attached thermal pad.

Selection Guide (RGS mounted on heatsink RHS37A)²

| Rated Output Voltage | Blocking Voltage | Connection Control/ Power | Control Voltage | Rated operational current @ 40°C |
|-------------------------|---------------------|------------------------------|--------------------|----------------------------------|
| | | | | 22 AAC |
| 230VAC, ZC | 800Vp | Screw/Screw | 3 - 32VDC | RGS1A23D50KKEH51 |
| | | Spring/Screw | 3 - 32VDC | RGS1A23D50MKEH51 |
| 600VAC, ZC | 1200Vp | Screw/Screw | 4 - 32VDC | RGS1A60D50KKEH51 |
| | | Spring/Screw | 4 - 32VDC | RGS1A60D50MKEH51 |

2: Any of the available RGS part nos. can be factory mounted upon request on heatsink RHS37A. The above are some part no. examples of RGS with factory mounted heatsink.

Output Voltage Specifications

| | | RGS..23.. | RGS..60.. |
|---------------------------|-----------------------------------|----------------------------------|---------------------------------|
| Operational Voltage Range | | 24-240 VAC, +10%, -15% on max | 42-600 VAC, +10% -15% on max |
| Blocking Voltage | RGS..25/50/75/90 RGS..51/71/91 | 800Vp - | 1200 Vp 1600 Vp |
| Internal Varistor | RGS..25/50/75/90 RGS..51/71/91 | 275V - | 625V 680V |

General Specifications

| | | | |
|---------------------------------|--|-----------------------|--|
| Latching voltage (across L1-T1) | ≤20V | Pollution degree | 2 (non-conductive pollution with possibilities of condensation) |
| Operational frequency range | 45 to 65Hz | Over-voltage category | III (fixed installations) |
| Power factor | > 0.5 @ Vrated | Isolation | |
| CE marking | Yes | Input to Output | 4000Vrms |
| Finger Protection | IP20 | Input&Output to Case | 4000Vrms |
| Control input status | continuously ON Green LED, when control input is applied | | |

Input specifications (@ 25°C unless otherwise specified)

| | | RGS..D.. ³ | RGS..A.. |
|------------------------------------|-----------|---------------------------|--|
| Control voltage range | RGS..23.. | 3 - 32 VDC | 20 - 275 VAC, 24 (-10%) - 190 VDC |
| | RGS..60.. | 4 - 32 VDC | 20 - 275 VAC, 24 (-10%) - 190 VDC |
| Pick-up voltage | RGS..23.. | 3.0 VDC | 20 VAC/DC |
| | RGS..60.. | 3.8 VDC | |
| Drop-out voltage | RGS..23.. | 1 VDC | 5 VAC/DC |
| | RGS..60.. | 1 VDC | |
| Maximum Reverse voltage | | 32 VDC | - |
| Response time pick-up ZC (RGS1A..) | | 0.5 cycle + 500µs @ 24VDC | 2 cycles @ 230VAC/110VDC |
| Response time pick-up IO (RGS1B..) | | 350µs @ 24 VDC | N/A |
| Response time drop-out | | 0.5 cycle + 500µs @ 24VDC | 0.5 cycle + 40ms @ 230 VAC/ 110 VDC |
| Input current @ 40°C | | See diagrams below | See diagrams below |

3: DC control to be supplied by a Class 2 power source

RG..D..

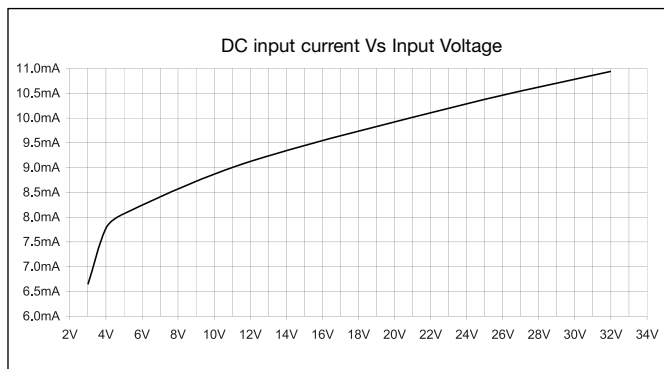

RG..A..

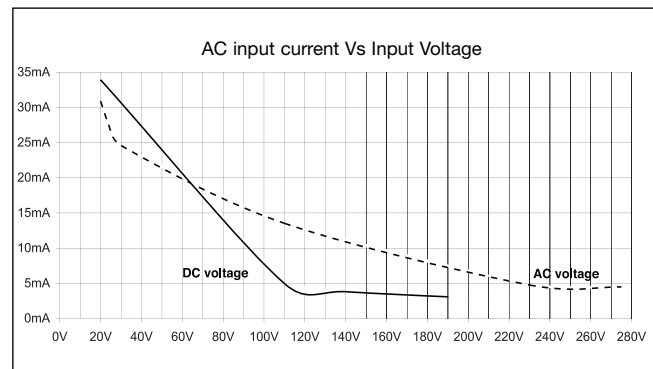

Motor Ratings⁴: HP (UL508) / kW (IEC60947-4-2) @ 40°C

| | 115 VAC | 230 VAC | 400 VAC | 480 VAC | 600 VAC |
|------------|----------------|----------------|--------------|-------------|---------------|
| RGS..25 | ½HP / 0.18kW | 1-½HP / 0.37kW | 3HP / 0.75kW | 3HP / 1.1kW | 5HP / 1.5kW |
| RGS..50/51 | 1HP / 0.37kW | 3HP / 1.1kW | 5HP / 1.5kW | 5HP / 2.2kW | 7-½HP / 3.7kW |
| RGS..75/71 | 1-½HP / 0.56kW | 3HP / 1.5kW | 5HP / 3kW | 7-½HP / 4kW | 10HP / 4kW |
| RGS..90/91 | 2HP / 0.75kW | 5HP / 2.2kW | 7-½HP / 4kW | 10HP / 4kW | 15HP / 5.5kW |

4: Refer to heatsink selection table

Output specifications

| | RGS..25.. | RGS..50/51.. | RGS..75/71.. | RGS..90/91.. |
|---|----------------------|----------------------|--|----------------------|
| Rated operational current AC51 @ Ta=40°C (IEC60947-4-3/UL508) ⁴ | 25 AAC | 50 AAC | 75 AAC | 90 AAC |
| AC-53a rating @ Ta=40°C (IEC60947-4-2/ UL508) | 5 AAC | 10 AAC | 14.8 AAC | 18 AAC |
| Number of motor starts (x:6, Tx:6s, F:50%) at 40°C ^{4,5} | 30 | 30 | 30 | 30 |
| Min. operational current | 150 mAAC | 250 mAAC | 400 mAAC | 400 mAAC |
| Rep. overload current - UL508: T _{AMB} =40°C, t _{ON} =1s, t _{OFF} =9s, 50cycles | 67 AAC | 107 AAC | 126 AAC | 168 AAC |
| Maximum Transient Surge Current (I _{TSM}) | 325Ap | 600Ap | 800Ap | 1150Ap |
| Maximum Off-state leakage current | 3 mAAC | 3 mAAC | 3 mAAC | 3 mAAC |
| I ² t (10ms) Typical | 525 A ² s | 1800A ² s | RG..75: 3200A ² s RG..71: 6600A ² s | 6600A ² s |
| Critical dv/dt (@ T _j init = 40°C) | 1000V/us | 1000V/us | 1000V/us | 1000V/us |

5 x: multiple of AC-53a current rating, Tx: duration of current surge, F: duty cycle.

Output Power Dissipation

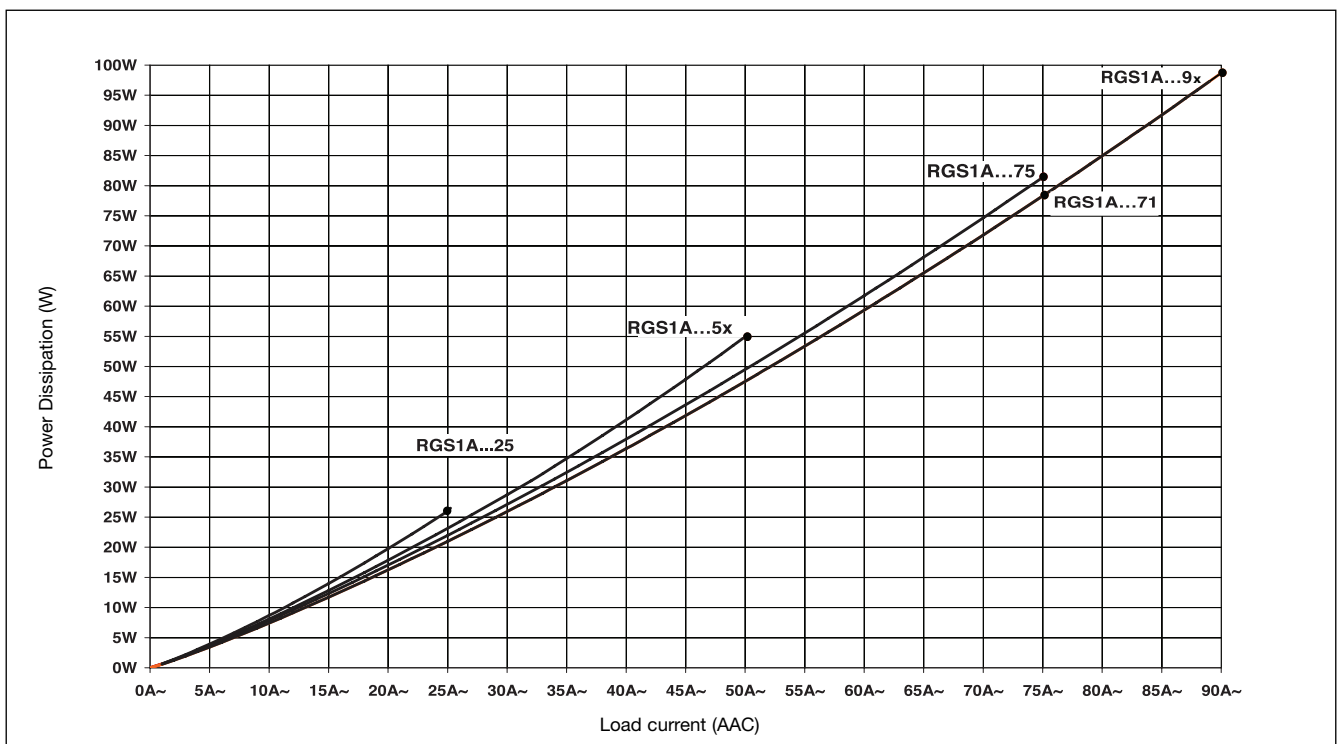

Electromagnetic Compatibility

| | | | |
|---|---|---|------------------------|
| EMC Immunity | IEC/EN 61000-6-2 | Radiated Radio Frequency Immunity | IEC/EN 61000-4-3 |
| Electrostatic Discharge (ESD) Immunity | IEC/EN 61000-4-2 | 10V/m, 80 - 1000 Mhz | Performance Criteria 1 |
| Air discharge, 8kV | Performance Criteria 1 | 10V/m, 1.4 - 2.0GHz | Performance Criteria 1 |
| Contact, 4kV | Performance Criteria 1 | 3 V/m, 2.0 - 2.7GHz | Performance Criteria 1 |
| Electrical Fast Transient (Burst) Immunity | IEC/EN 61000-4-4 | Conducted Radio Frequency Immunity | IEC/EN 61000-4-6 |
| Output: 2kV, 5kHz | Performance Criteria 1 | 10V/m, 0.15 - 80 MHz | Performance Criteria 1 |
| Input: 1kV, 5kHz | Performance Criteria 1 | Voltage Dips Immunity | IEC/EN 61000-4-11 |
| Electrical Surge Immunity | IEC/EN 61000-4-5 | 0% for 10ms/20ms | Performance Criteria 2 |
| Output, line to line, 1kV | Performance Criteria 1 | 40% for 200ms | Performance Criteria 2 |
| Output, line to earth, 2kV | Performance Criteria 1 | 70% for 500ms | Performance Criteria 2 |
| Input, line to line, 1kV | Performance Criteria 2 | Voltage Interruptions Immunity | IEC/EN 61000-4-11 |
| Input, line to earth, 2kV | Performance Criteria 2 | 0% for 5000ms | Performance Criteria 2 |
| EMC Emission | IEC/EN 61000-6-4 | Radio Interference | |
| Radio Interference | | Field Emission (Radiated) | IEC/EN 55011 |
| Voltage Emission (Conducted) | IEC/EN 55011 | 30 - 1000MHz | Class A (industrial) |
| 0.15 - 30MHz | Class A (industrial) with filters - see filter information | | |
| | IEC/EN 60947-4-2, 60947-4-3 | | |
| | Class A (no filtering needed) | | |

Filtering - IEC/EN 55011 Class A compliance (for class B compliance contact us)

| Part Number | Suggested filter for compliance | Maximum Heater current |
|-------------------|---------------------------------|------------------------|
| RGS1A23..25 | 100 nF / 275 V / X1 | 25 A |
| RGS1A23..50 | 220 nF / 275 V / X1 | 30 A |
| | 330 nF / 275 V / X1 | 35 A |
| RGS1A23..51 | 150 nF / 275 V / X1 | 20 A |
| | 220 nF / 275 V / X1 | 35 A |
| RGS1A23..75 | 330 nF / 275 V / X1 | 35 A |
| RGS1A23..71/90/91 | 330 nF / 275 V / X1 | 35 A |
| RGS1A60..25 | 150 nF / 760 V / X1 | 25 A |
| | 220 nF / 760 V / X1 | 30 A |
| RGS1A60..50 | 330 nF / 760 V / X1 | 30 A |
| RGS1A60..51 | 220 nF / 760 V / X1 | 30 A |
| RGS1A60..75 | 220 nF / 760 V / X1 | 30 A |
| RGS1A60..71/90/91 | 220 nF / 760 V / X1 | 30 A |

Note:

- Control input lines must be installed together to maintain products' susceptibility to Radio Frequency interference. Use of AC solid state relays may, according to the application and the load current, cause conducted radio interferences. Use of mains filters may be necessary for cases where the user must meet E.M.C requirements. The capacitor values given inside the filtering specification tables should be taken only as indications, the filter attenuation will depend on the final application. DC input type require surge suppression for full compliance to EN55011.
- Performance Criteria 1: No degradation of performance or loss of function is allowed when the product is operated as intended.
- Performance Criteria 2: During the test, degradation of performance or partial loss of function is allowed. However when the test is complete the product should return operating as intended by itself.
- Performance Criteria 3: Temporary loss of function is allowed, provided the function can be restored by manual operation of the controls.

Filter Connection diagram

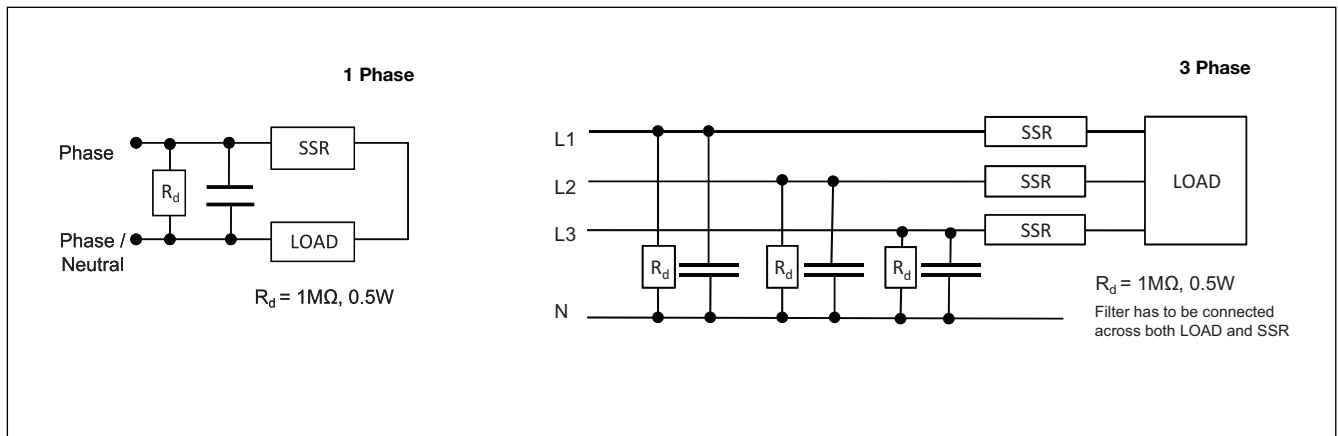

Terminal Layout and Dimensions

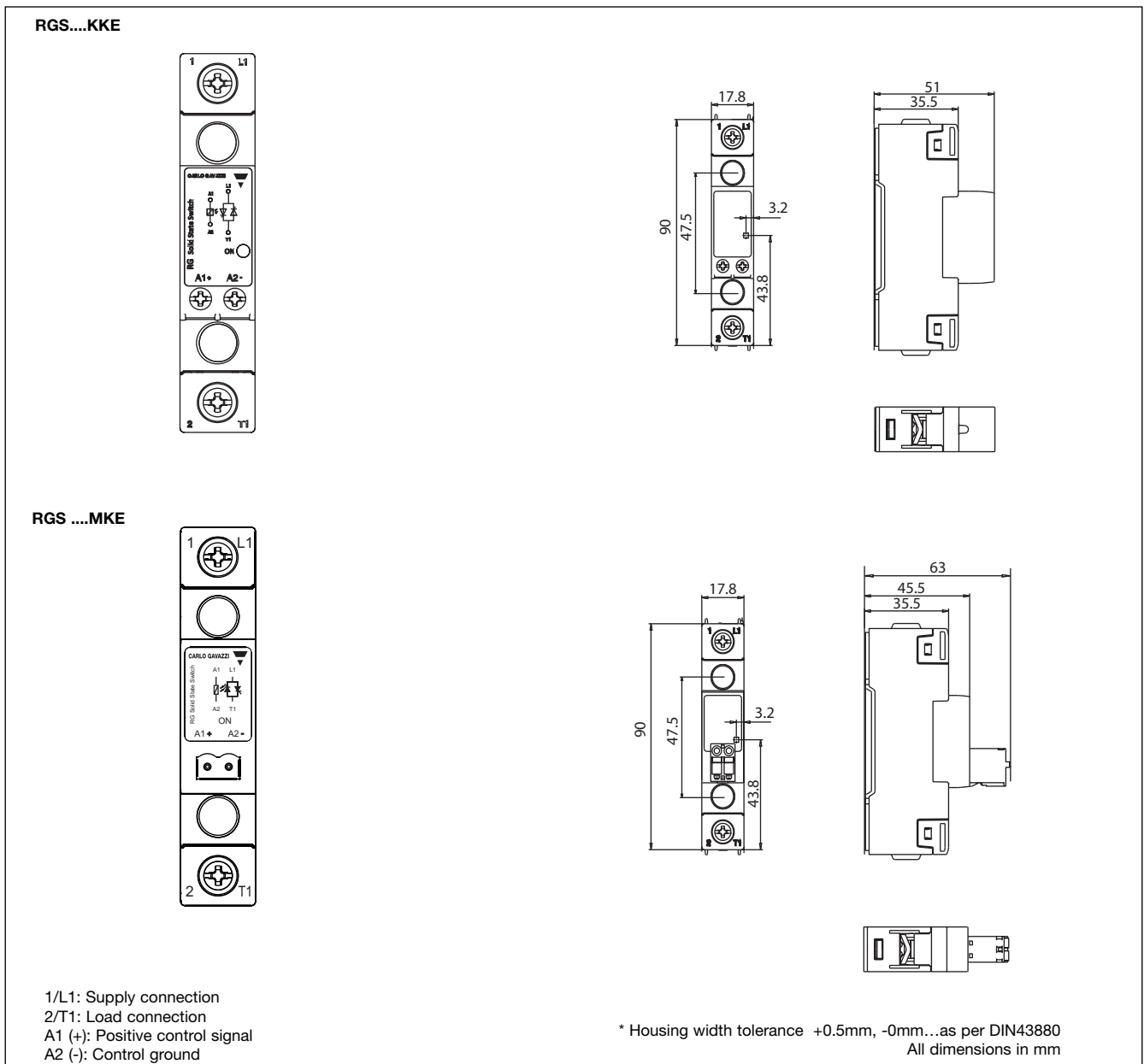

Connection Specifications

POWER CONNECTIONS: 1/L1, 2 /T1

Torque specifications



2 Nm (17.7 in-lb)
M4, Pozidriv 2
Use 75°C copper (Cu)
conductors
Stripping Length (X) = 12mm

Rigid (Solid & Stranded)

UL/ CSA rated data

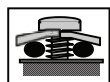
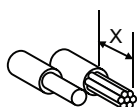

2 x 2.5..6 mm²
2 x 14..10 AWG

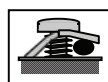

1 x 2.5..6 mm²
1 x 14..10 AWG

Flexible with end sleeve



2 x 1.0...2.5mm²
2 x 2.5...4mm² 1 x 1.0...4mm²
2 x 18...14 AWG 1 x 18...12AWG
2 x 14...12AWG

Flexible without end sleeve



2 x 1.0...2.5mm²
2 x 2.5..6 mm² 1 x 1.0...6 mm²
2 x 18 ...14AWG 1 x 18...10AWG
2 x 14...10AWG

Aperture for termination lug

12.3mm

CONTROL CONNECTIONS: A1(+), A2(-) for RGS...KKE

Torque specifications



0.5 Nm (4.4 in-lb)
M3, Pozidriv 1
Use 60/75°C copper (Cu)
conductors
Stripping Length (X) = 8mm

Rigid (Solid & Stranded)

UL/ CSA rated data

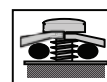
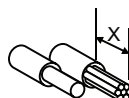

2 x 0.5..2.5mm²
2 x 18..12 AWG



1 x 0.5..2.5mm²
1 x 18..12 AWG

Flexible with end sleeve



2 x 0.5..2.5mm² 1 x 0.5..2.5mm²
2 x 18..12AWG 1 x 18..12AWG

CONTROL CONNECTIONS: A1(+), A2(-) for RGS...MKE

Use 60/75°C copper (Cu) conductors

Stripping Length (X)

12 - 13mm

Rigid (Stranded)

UL/ cUL rated data

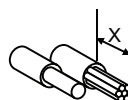

1 x 0.2...2.5mm²
1 x 24 ... 12 AWG

Environmental Specifications

| | | | |
|--------------------------------------|-------------------------------------|--|---------------------------|
| Operating Temperature | -40°C to 80°C (-40°F to +176°F) | Vibration resistance (2-100Hz, IEC60068-2-26) | 5g |
| Storage Temperature | -40°C to 100°C (-40°F to +212°F) | Relative humidity | 95% non-condensing @ 40°C |
| RoHS (2002/95/EC) | Compliant | UL flammability rating (housing) | UL 94 V0 |
| Impact resistance (IEC60068-2-27) | 15/11 g/ms | | |

Agency Approvals and Conformances

| | | | |
|-------------|--|------------------------------|--|
| Conformance | IEC/EN 62314 IEC/EN 60947-4-2 IEC/EN 60947-4-3 | Agency Approvals | UL508 Recognised (E172877) CSA 22.2 No.14-10 (204075) VDE (0660-109) |
| | | Short Circuit Current rating | 100kA, UL508 |



Connection Diagram

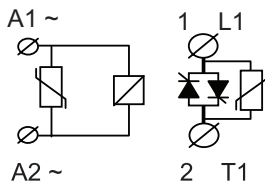

In AC controlled types only (RG..A..) a varistor is placed across A1/A2 terminals.

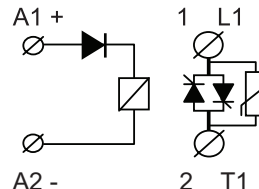

In DC controlled types only (RG..D..) a diode is placed in series with the control circuit for protection against reverse biased connection.

Heatsink Selection

RGS1...25

| Load current [A] | Thermal resistance [K/W] | | | | | | | Power dissipation [W] |
|------------------|--------------------------|-------|-------|-------|-------|-------|-------|-----------------------|
| | 20 | 30 | 40 | 50 | 60 | 70 | 80 | |
| 25.0 | 3.11 | 2.72 | 2.33 | 1.94 | 1.55 | 1.17 | 0.78 | 25.7 |
| 22.5 | 3.55 | 3.10 | 2.66 | 2.22 | 1.77 | 1.33 | 0.89 | 22.6 |
| 20.0 | 4.10 | 3.59 | 3.08 | 2.56 | 2.05 | 1.54 | 1.03 | 19.5 |
| 17.5 | 4.83 | 4.23 | 3.63 | 3.02 | 2.42 | 1.81 | 1.21 | 16.6 |
| 15.0 | 5.83 | 5.10 | 4.37 | 3.64 | 2.91 | 2.18 | 1.46 | 13.7 |
| 12.5 | 7.24 | 6.34 | 5.43 | 4.53 | 3.62 | 2.72 | 1.81 | 11.0 |
| 10.0 | 9.43 | 8.25 | 7.07 | 5.89 | 4.71 | 3.54 | 2.36 | 8.5 |
| 7.5 | 13.17 | 11.53 | 9.88 | 8.23 | 6.59 | 4.94 | 3.29 | 6.1 |
| 5.0 | 20.97 | 18.35 | 15.73 | 13.11 | 10.49 | 7.86 | 5.24 | 3.8 |
| 2.5 | 45.89 | 40.15 | 34.42 | 28.68 | 22.94 | 17.21 | 11.47 | 1.7 |

T_A
Ambient temp [°C]

RGS1...5x

| Load current [A] | Thermal resistance [K/W] | | | | | | | Power dissipation [W] |
|------------------|--------------------------|-------|-------|-------|-------|------|------|-----------------------|
| | 20 | 30 | 40 | 50 | 60 | 70 | 80 | |
| 50.0 | 1.45 | 1.28 | 1.06 | 0.87 | 0.68 | 0.49 | 0.30 | 52.8 |
| 45.0 | 1.72 | 1.50 | 1.29 | 1.07 | 0.85 | 0.64 | 0.42 | 46.3 |
| 40.0 | 2.00 | 1.75 | 1.50 | 1.25 | 1.00 | 0.75 | 0.50 | 40.0 |
| 35.0 | 2.35 | 2.06 | 1.76 | 1.47 | 1.18 | 0.88 | 0.59 | 34.0 |
| 30.0 | 2.83 | 2.48 | 2.13 | 1.77 | 1.42 | 1.06 | 0.71 | 28.2 |
| 25.0 | 3.52 | 3.08 | 2.64 | 2.20 | 1.76 | 1.32 | 0.88 | 22.7 |
| 20.0 | 4.58 | 4.01 | 3.44 | 2.86 | 2.29 | 1.72 | 1.15 | 17.5 |
| 15.0 | 6.40 | 5.60 | 4.80 | 4.00 | 3.20 | 2.40 | 1.60 | 12.5 |
| 10.0 | 10.19 | 8.92 | 7.64 | 6.37 | 5.10 | 3.82 | 2.55 | 7.8 |
| 5.0 | 22.30 | 19.51 | 16.72 | 13.94 | 11.15 | 8.36 | 5.57 | 3.6 |

T_A
Ambient temp [°C]

| | |
|---|------------|
| Maximum junction temperature | 125°C |
| Heatsink temperature | 100°C |
| Junction to case thermal resistance, R _{thjc} | <0.45 K/W |
| Case to heatsink thermal resistance, R _{thcs} ⁶ | < 0.25 K/W |

| | |
|---|------------|
| Maximum junction temperature | 125°C |
| Heatsink temperature | 100°C |
| Junction to case thermal resistance, R _{thjc} | <0.3 K/W |
| Case to heatsink thermal resistance, R _{thcs} ⁶ | < 0.25 K/W |

Heatsink Selection (cont.)

RGS1...71

| Load current [A] | Thermal resistance [K/W] | | | | | | | Power dissipation [W] |
|------------------|--------------------------|-------|-------|------|------|------|------|-----------------------|
| | 20 | 30 | 40 | 50 | 60 | 70 | 80 | |
| 75.0 | 0.90 | 0.77 | 0.64 | 0.51 | 0.38 | 0.26 | 0.13 | 77.9 |
| 67.5 | 1.09 | 0.94 | 0.80 | 0.65 | 0.50 | 0.36 | 0.21 | 68.2 |
| 60.0 | 1.33 | 1.16 | 0.99 | 0.82 | 0.65 | 0.48 | 0.31 | 58.9 |
| 52.5 | 1.60 | 1.40 | 1.20 | 1.00 | 0.80 | 0.60 | 0.40 | 49.9 |
| 45.0 | 1.93 | 1.69 | 1.45 | 1.21 | 0.97 | 0.73 | 0.48 | 41.4 |
| 37.5 | 2.41 | 2.11 | 1.81 | 1.50 | 1.20 | 0.90 | 0.60 | 33.2 |
| 30.0 | 3.14 | 2.74 | 2.35 | 1.96 | 1.57 | 1.18 | 0.78 | 25.5 |
| 22.5 | 4.39 | 3.84 | 3.29 | 2.74 | 2.19 | 1.65 | 1.10 | 18.2 |
| 15.0 | 6.99 | 6.12 | 5.24 | 4.37 | 3.50 | 2.62 | 1.75 | 11.4 |
| 7.5 | 15.29 | 13.38 | 11.47 | 9.56 | 7.65 | 5.73 | 3.82 | 5.2 |

Ambient temp [°C]

| | |
|---|------------|
| Maximum junction temperature | 125°C |
| Heatsink temperature | 100°C |
| Junction to case thermal resistance, Rthjc | <0.2 K/W |
| Case to heatsink thermal resistance, Rthcs ⁶ | < 0.25 K/W |

RGS1...75

| Load current [A] | Thermal resistance [K/W] | | | | | | | Power dissipation [W] |
|------------------|--------------------------|-------|-------|------|------|------|------|-----------------------|
| | 20 | 30 | 40 | 50 | 60 | 70 | 80 | |
| 75.0 | 0.80 | 0.68 | 0.55 | 0.43 | 0.30 | 0.18 | 0.06 | 80.7 |
| 67.5 | 0.99 | 0.84 | 0.70 | 0.56 | 0.42 | 0.28 | 0.14 | 70.7 |
| 60.0 | 1.22 | 1.06 | 0.89 | 0.73 | 0.56 | 0.40 | 0.24 | 61.0 |
| 52.5 | 1.53 | 1.33 | 1.14 | 0.95 | 0.76 | 0.56 | 0.37 | 51.8 |
| 45.0 | 1.86 | 1.63 | 1.40 | 1.16 | 0.93 | 0.70 | 0.47 | 42.9 |
| 37.5 | 2.32 | 2.03 | 1.74 | 1.45 | 1.16 | 0.87 | 0.58 | 34.5 |
| 30.0 | 3.01 | 2.64 | 2.26 | 1.88 | 1.51 | 1.13 | 0.75 | 26.5 |
| 22.5 | 4.21 | 3.68 | 3.16 | 2.63 | 2.10 | 1.58 | 1.05 | 19.0 |
| 15.0 | 6.68 | 5.85 | 5.01 | 4.18 | 3.34 | 2.51 | 1.67 | 12.0 |
| 7.5 | 14.53 | 12.71 | 10.89 | 9.08 | 7.26 | 5.45 | 3.63 | 5.5 |

Ambient temp [°C]

| | |
|---|------------|
| Maximum junction temperature | 125°C |
| Heatsink temperature | 100°C |
| Junction to case thermal resistance, Rthjc | <0.25 K/W |
| Case to heatsink thermal resistance, Rthcs ⁶ | < 0.25 K/W |

RGS1...9x

| Load current [A] | Thermal resistance [K/W] | | | | | | | Power dissipation [W] |
|------------------|--------------------------|-------|------|------|------|------|------|-----------------------|
| | 20 | 30 | 40 | 50 | 60 | 70 | 80 | |
| 90.0 | 0.62 | 0.52 | 0.41 | 0.31 | 0.21 | 0.11 | 0.01 | 98.4 |
| 81.0 | 0.77 | 0.66 | 0.54 | 0.42 | 0.31 | 0.19 | 0.07 | 85.9 |
| 72.0 | 0.97 | 0.83 | 0.70 | 0.56 | 0.43 | 0.29 | 0.16 | 74.0 |
| 63.0 | 1.23 | 1.07 | 0.91 | 0.75 | 0.59 | 0.43 | 0.27 | 62.5 |
| 54.0 | 1.55 | 1.35 | 1.16 | 0.97 | 0.77 | 0.58 | 0.39 | 51.7 |
| 45.0 | 1.93 | 1.69 | 1.45 | 1.21 | 0.97 | 0.73 | 0.48 | 41.4 |
| 36.0 | 2.53 | 2.21 | 1.89 | 1.58 | 1.26 | 0.95 | 0.63 | 31.6 |
| 27.0 | 3.55 | 3.11 | 2.66 | 2.22 | 1.77 | 1.33 | 0.89 | 22.5 |
| 18.0 | 5.67 | 4.97 | 4.26 | 3.55 | 2.84 | 2.13 | 1.42 | 14.1 |
| 9.0 | 12.46 | 10.90 | 9.34 | 7.79 | 6.23 | 4.67 | 3.11 | 6.4 |

Ambient temp [°C]

| | |
|---|------------|
| Maximum junction temperature | 125°C |
| Heatsink temperature | 100°C |
| Junction to case thermal resistance, Rthjc | <0.20 K/W |
| Case to heatsink thermal resistance, Rthcs ⁶ | < 0.25 K/W |

6: Thermal resistance case to heatsink valves are applicable upon application of a fine layer of silicon based thermal paste HTS02S from Electrolube between SSR and heatsink.

Mounting Instructions

Thermal stress will reduce the lifetime of the SSR. Therefore it is necessary to select the appropriate heatsinks, taking into account the surrounding temperature, load current and the duty cycle.

A small amount of thermally conductive silicone paste must be applied to the back of the SSR. RGS should be mounted on the heatsink with two M5 screws. Gradually tighten each screw (alternating between the two) until both

are tightened with a torque of 0.75Nm. For optimal results wait one hour to allow excess paste to be pressed out and then tighten both screws to their final mounting torque of 1.5Nm.

In case of a thermal pad attached to the back of the SSR, no thermal paste is required. The RGS is gradually tightened (altering between the 2 screws) to a maximum torque of 1.5Nm.

Heatsink Selection for RGS...HT

RGS1...25..HT

| Load current [A] | Thermal resistance [K/W] | | | | | | | Power dissipation [W] |
|------------------|--------------------------|-------|-------|-------|-------|-------|-------|-----------------------|
| | 20 | 30 | 40 | 50 | 60 | 70 | 80 | |
| 25.0 | 2.73 | 2.34 | 1.95 | 1.56 | 1.18 | 0.79 | 0.40 | 25.7 |
| 22.5 | 3.30 | 2.86 | 2.42 | 1.97 | 1.53 | 1.09 | 0.64 | 22.6 |
| 20.0 | 4.04 | 3.52 | 3.01 | 2.50 | 1.98 | 1.47 | 0.96 | 19.5 |
| 17.5 | 4.83 | 4.23 | 3.63 | 3.02 | 2.42 | 1.81 | 1.21 | 16.6 |
| 15.0 | 5.83 | 5.10 | 4.37 | 3.64 | 2.91 | 2.18 | 1.46 | 13.7 |
| 12.5 | 7.24 | 6.34 | 5.43 | 4.53 | 3.62 | 2.72 | 1.81 | 11.0 |
| 10.0 | 9.43 | 8.25 | 7.07 | 5.89 | 4.71 | 3.54 | 2.36 | 8.5 |
| 7.5 | 13.17 | 11.53 | 9.88 | 8.23 | 6.59 | 4.94 | 3.29 | 6.1 |
| 5.0 | 20.97 | 18.35 | 15.73 | 13.11 | 10.49 | 7.86 | 5.24 | 3.8 |
| 2.5 | 45.89 | 40.15 | 34.42 | 28.68 | 22.94 | 17.21 | 11.47 | 1.7 |

Ambient temp [°C]

RGS1...5x..HT

| Load current [A] | Thermal resistance [K/W] | | | | | | Power dissipation [W] | |
|------------------|--------------------------|-------|-------|-------|-------|------|-----------------------|------|
| | 20 | 30 | 40 | 50 | 60 | 70 | | 80 |
| 50.0 | 0.84 | 0.65 | 0.46 | 0.27 | 0.08 | --- | --- | 52.8 |
| 45.0 | 1.12 | 0.90 | 0.69 | 0.47 | 0.25 | 0.04 | --- | 46.3 |
| 40.0 | 1.47 | 1.22 | 0.97 | 0.72 | 0.47 | 0.22 | --- | 40.0 |
| 35.0 | 1.94 | 1.64 | 1.35 | 1.06 | 0.76 | 0.47 | 0.17 | 34.0 |
| 30.0 | 2.57 | 2.22 | 1.86 | 1.51 | 1.15 | 0.80 | 0.44 | 28.2 |
| 25.0 | 3.48 | 3.03 | 2.59 | 2.15 | 1.71 | 1.27 | 0.83 | 22.7 |
| 20.0 | 4.58 | 4.01 | 3.44 | 2.86 | 2.29 | 1.72 | 1.15 | 17.5 |
| 15.0 | 6.40 | 5.60 | 4.80 | 4.00 | 3.20 | 2.40 | 1.60 | 12.5 |
| 10.0 | 10.19 | 8.92 | 7.64 | 6.37 | 5.10 | 3.82 | 2.55 | 7.8 |
| 5.0 | 22.30 | 19.51 | 16.72 | 13.94 | 11.15 | 8.36 | 5.57 | 3.6 |

Ambient temp [°C]

| | |
|--|-----------|
| Maximum junction temperature | 125°C |
| Heatsink temperature | 100°C |
| Junction to case thermal resistance, Rthjc | <0.45 K/W |
| Case to heatsink thermal resistance, Rthcs | < 0.9 K/W |

| | |
|--|------------|
| Maximum junction temperature | 125°C |
| Heatsink temperature | 100°C |
| Junction to case thermal resistance, Rthjc | <0.3 K/W |
| Case to heatsink thermal resistance, Rthcs | < 0.85 K/W |

Heatsink Selection for RGS...HT (cont.)

RGS1...71..HT

| Load current [A] | Thermal resistance [K/W] | | | | | | | Power dissipation [W] |
|------------------|--------------------------|-------|-------|------|------|------|------|-----------------------|
| | 20 | 30 | 40 | 50 | 60 | 70 | 80 | |
| 75.0 | 0.35 | 0.22 | 0.09 | --- | --- | --- | --- | 77.9 |
| 67.5 | 0.54 | 0.39 | 0.25 | 0.10 | --- | --- | --- | 68.2 |
| 60.0 | 0.78 | 0.61 | 0.44 | 0.27 | 0.10 | --- | --- | 58.9 |
| 52.5 | 1.10 | 0.90 | 0.70 | 0.50 | 0.30 | 0.10 | --- | 49.9 |
| 45.0 | 1.54 | 1.30 | 1.05 | 0.81 | 0.57 | 0.33 | 0.09 | 41.4 |
| 37.5 | 2.16 | 1.86 | 1.56 | 1.26 | 0.96 | 0.66 | 0.35 | 33.2 |
| 30.0 | 3.12 | 2.72 | 2.33 | 1.94 | 1.55 | 1.16 | 0.76 | 25.5 |
| 22.5 | 4.39 | 3.84 | 3.29 | 2.74 | 2.19 | 1.65 | 1.10 | 18.2 |
| 15.0 | 6.99 | 6.12 | 5.24 | 4.37 | 3.49 | 2.62 | 1.75 | 11.4 |
| 7.5 | 15.29 | 13.38 | 11.47 | 9.56 | 7.64 | 5.73 | 3.82 | 5.2 |

Ambient temp [°C]

| | |
|--|-----------|
| Maximum junction temperature | 125°C |
| Heatsink temperature | 100°C |
| Junction to case thermal resistance, Rthjc | <0.2 K/W |
| Case to heatsink thermal resistance, Rthcs | < 0.8 K/W |

RGS1...75..HT

| Load current [A] | Thermal resistance [K/W] | | | | | | | Power dissipation [W] |
|------------------|--------------------------|-------|-------|------|------|------|------|-----------------------|
| | 20 | 30 | 40 | 50 | 60 | 70 | 80 | |
| 75.0 | 0.25 | 0.13 | 0.00 | --- | --- | --- | --- | 80.7 |
| 67.5 | 0.44 | 0.29 | 0.15 | 0.01 | --- | --- | --- | 70.7 |
| 60.0 | 0.67 | 0.51 | 0.34 | 0.18 | 0.01 | --- | --- | 61.0 |
| 52.5 | 0.98 | 0.78 | 0.59 | 0.40 | 0.21 | 0.01 | --- | 51.8 |
| 45.0 | 1.39 | 1.16 | 0.93 | 0.70 | 0.46 | 0.23 | --- | 42.9 |
| 37.5 | 1.99 | 1.70 | 1.41 | 1.12 | 0.83 | 0.54 | 0.25 | 34.5 |
| 30.0 | 2.91 | 2.53 | 2.15 | 1.78 | 1.40 | 1.02 | 0.65 | 26.5 |
| 22.5 | 4.21 | 3.68 | 3.16 | 2.63 | 2.10 | 1.58 | 1.05 | 19.0 |
| 15.0 | 6.68 | 5.85 | 5.01 | 4.18 | 3.34 | 2.51 | 1.67 | 12.0 |
| 7.5 | 14.53 | 12.71 | 10.89 | 9.08 | 7.26 | 5.45 | 3.63 | 5.5 |

Ambient temp [°C]

| | |
|--|------------|
| Maximum junction temperature | 125°C |
| Heatsink temperature | 100°C |
| Junction to case thermal resistance, Rthjc | <0.25 K/W |
| Case to heatsink thermal resistance, Rthcs | < 0.80 K/W |

RGS1...9x..HT

| Load current [A] | Thermal resistance [K/W] | | | | | | | Power dissipation [W] |
|------------------|--------------------------|-------|------|------|------|------|------|-----------------------|
| | 20 | 30 | 40 | 50 | 60 | 70 | 80 | |
| 90.0 | 0.07 | --- | --- | --- | --- | --- | --- | 98.4 |
| 81.0 | 0.22 | 0.11 | --- | --- | --- | --- | --- | 85.9 |
| 72.0 | 0.42 | 0.28 | 0.15 | 0.01 | --- | --- | --- | 74.0 |
| 63.0 | 0.68 | 0.52 | 0.36 | 0.20 | 0.04 | --- | --- | 62.5 |
| 54.0 | 1.03 | 0.84 | 0.65 | 0.45 | 0.26 | 0.06 | --- | 51.7 |
| 45.0 | 1.54 | 1.30 | 1.05 | 0.81 | 0.57 | 0.33 | 0.09 | 41.4 |
| 36.0 | 2.32 | 2.00 | 1.69 | 1.37 | 1.05 | 0.74 | 0.42 | 31.6 |
| 27.0 | 3.55 | 3.11 | 2.66 | 2.22 | 1.77 | 1.33 | 0.89 | 22.5 |
| 18.0 | 5.67 | 4.97 | 4.26 | 3.55 | 2.84 | 2.13 | 1.42 | 14.1 |
| 9.0 | 12.46 | 10.90 | 9.34 | 7.79 | 6.23 | 4.67 | 3.11 | 6.4 |

Ambient temp [°C]

| | |
|--|------------|
| Maximum junction temperature | 125°C |
| Heatsink temperature | 100°C |
| Junction to case thermal resistance, Rthjc | <0.20 K/W |
| Case to heatsink thermal resistance, Rthcs | < 0.80 K/W |

Short Circuit Protection

Protection Co-ordination, Type 1 vs Type 2:

Type 1 protection implies that after a short circuit, the device under test will no longer be in a functioning state. In type 2 co-ordination the device under test will still be functional after the short circuit. In both cases, however the short circuit has to be interrupted. The fuse between enclosure and supply shall not open. The door or cover of the enclosure shall not be blown open. There shall be no damage to conductors or terminals and the conductors shall not separate from terminals. There shall be no breakage or cracking of insulating bases to the extent that the integrity of the mounting of live parts is impaired. Discharge of parts or any risk of fire shall not occur.

The product variants listed in the table hereunder are suitable for use on a circuit capable of delivering not more than 100,000A rms Symmetrical Amperes, 600Volts maximum when protected by fuses. Tests at 100,000A were performed with Class J, fast acting; please refer to the table below for maximum allowed ampere rating of the fuse. Use fuses only.

Co-ordination type 1 (UL508)

| Part no. | Max. size [A] | Class | Current [kA] | Voltage [VAC] |
|--------------|---------------|-------|--------------|---------------|
| RGS..25 | 30 | J | 100 | Max. 600 |
| RGS..50 / 51 | 30 | J | 100 | Max. 600 |
| RGS..75 / 71 | 30 | J | 100 | Max. 600 |
| RGS..90 / 91 | 30 | J | 100 | Max. 600 |

Note: For the RGS..50,51,75,71,90,91, the fuse rating are according to the motor rating as required by the UL standard.

Co-ordination type 2 (IEC/EN 60947-4-2/ -4-3)

| Part No. | Ferraz Shawmut | | Siba | | Current [kA] | Voltage [VAC] |
|---------------|----------------|---|--------------|---------------|--------------|---------------|
| | Max size [A] | Part number | Max size [A] | Part number | | |
| RGS..25 | 32 | 6.9xx CP URD 22x58/32, (xx=00 or 21) | - | - | 100 | Max. 600 |
| RGS..50 | 50 | A70QS50-4 | 50 | 50 142 06.50 | 100 | Max. 600 |
| RGS..51 | 50 | A70QS50-4 | - | - | 100 | Max. 600 |
| RGS..75 | 80 | A70QS80-4 | - | - | 100 | Max. 600 |
| RGS..71/90/91 | 100 | A70QS100-4 | 100 | 50 194 20.100 | 100 | Max. 600 |

Protection with Miniature Circuit Breakers

| Solid State Relay type | Model no. for Z - type M. C. B. (rated current) | Model no. for B - type M. C. B. (rated current) | Wire cross sectional area [mm ²] | Minimum length of Cu wire conductor [m] ⁷ | |
|---|---|---|--|--|------|
| RGS..25 | S201 - Z4 (4A) | S201 - B2 (2A) | 1.0 | 21.0 | |
| | S201 - Z6 UC (6A) | S201 - B2 (2A) | 1.0 | 21.0 | |
| | | | 1.5 | 31.5 | |
| RGS..50 RGS..51 | S201 - Z10 (10A) | S201-B4 (4A) | 1.0 | 7.6 | |
| | | | 1.5 | 11.4 | |
| | | | 2.5 | 19.0 | |
| | S201 - Z16 (16A) | S201-B6 (6A) | 1.0 | 5.2 | |
| | | | 1.5 | 7.8 | |
| | | | 2.5 | 13.0 | |
| | | | 4.0 | 20.8 | |
| | S201 - Z20 (20A) | S201-B10 (10A) | 1.5 | 12.6 | |
| | | | 2.5 | 21.0 | |
| | S201 - Z25 (25A) | S201-B13 (13A) | 2.5 | 25.0 | |
| | | | 4.0 | 40.0 | |
| | S202 - Z25 (25A) | S202-B13 (13A) | 2.5 | 19.0 | |
| | | | 4.0 | 30.4 | |
| | RGS..75 | S201 - Z25 (25A) | S201-B13 (13A) | 2.5 | 7.0 |
| | | | | 4.0 | 11.2 |
| 6.0 | | | | 16.8 | |
| RGS...71, RGS...90, RGS...91 | S201 - Z20 (20A) | S201-B10 (10A) | 1.5 | 4.2 | |
| | | | 2.5 | 7.0 | |
| | | | 4.0 | 11.2 | |
| | S202 - Z20 (20A) | S202-B10 (10A) | 1.5 | 1.8 | |
| | | | 2.5 | 3.0 | |
| | | | 4.0 | 4.8 | |
| | S201 - Z32 (32A) | S201-B16 (16A) | 2.5 | 13.0 | |
| | | | 4.0 | 20.8 | |
| | | | 6.0 | 31.2 | |
| | S202 - Z32 (32A) | S202-B16 (16A) | 2.5 | 5.0 | |
| | | | 4.0 | 8.0 | |
| | | | 6.0 | 12.0 | |
| | | | 10.0 | 20.0 | |
| | S202 - Z50 (50A) | S202-B25 (25A) | 4.0 | 14.8 | |
| | | | 6.0 | 22.2 | |
| 10.0 | | | 37.0 | | |

7. between MCB and SSR Relay (including return path which goes back to the mains).

Note: A prospective current of 6kA and a 230/400V power supply system is assumed for the above suggested specifications. For cables with different cross section than those mentioned above please consult Carlo Gavazzi's Technical Support Group.

Accessories

Thermal Pads



Ordering Key

Thermal pad
mounted on RGS

RGS...HT

Pack of 10 thermal pads
size 34.6 x 14mm

RGHT

Control Plugs



Ordering Key

Pack of 10 spring
loaded control plugs

RGM25

* Refer to 'Connection Specifications' section for further details.

Accessories (cont.)

Heatsink RHS37A



Ordering Key

Heatsink with
DIN rail clip

RHS37A

Factory mounted
heatsink to RGS

RGS...H51

RHS37A Dimensions

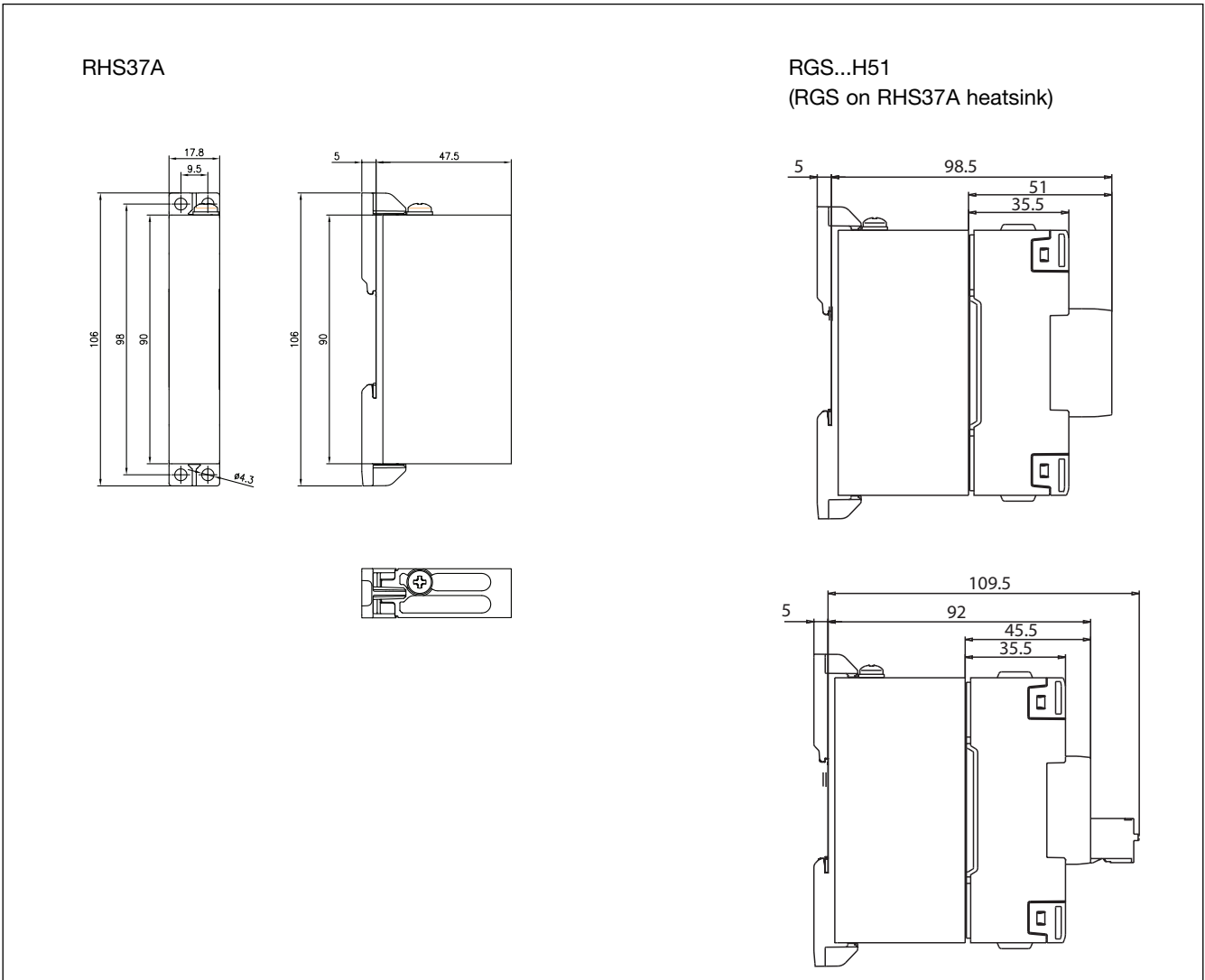

Accessories (cont.)

Derating Curves (RGS assembled to heatsink RHS37A)

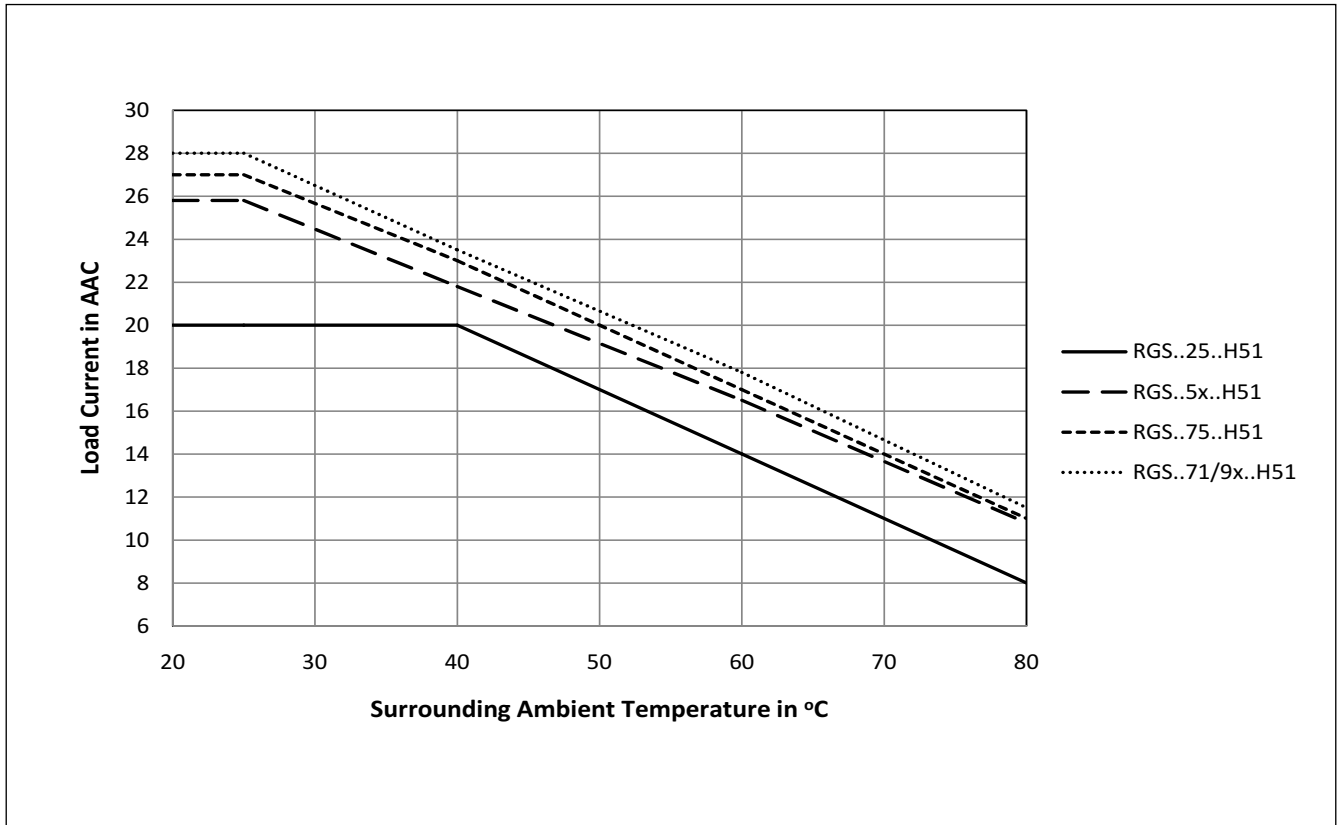

RHS37A Thermal Resistance Curve

